



TECHNICAL DATASHEET TWIN MAX

The CMCE-SERTEC is a revolutionary electro-atmospheric protection system that combines innovative electric field compensation technology with intelligent adaptive capability.



Definition

The CMCE (Multiple Electric Field Compensator) is a lightning protection system that prevents the formation of lightning. It is defined as a passive continuous collector of electrostatic currents, which directs them to the ground. Its principle of operation is based on balancing or compensating the variable electric field present in its environment, preventing the conditions for the formation of the upward leader in the CMCE and the protected structure within its coverage radius.

Operating Principle

Each capacitor has one of its electrodes referenced to ground, which is charged with the same polarity as the ground. The free electrode induces atmospheric charges of opposite polarity to that of the ground, achieving internal balance between its electrodes, which generates a potential difference. This results in a flow of charges to the ground, which are absorbed from the atmosphere, preventing the formation of lightning within its coverage radius.

Certifications and Compliance

- Complies with IEC, EN, UNE-EN and BS-EN 62305 Part 1,2,3,4.
- Complies with UL 96 (For a specific device)
- Complies with RoHS regulations.
- It has CE marking.
- It has UCKA Marking.
- ISO 9001:2015
- ISO 14001:2015
- Compliance with the community of Independent States.
- Approved by the TESLA institute based on:
 - IEC 60060-1:2010 High voltage test techniques Part 1: General definitions and test requirements
 - IEC 60060-2:2010 High voltage test techniques - Part 2: Measurement systems
- SERTEC S.R.L. It is approved within the NATO Cataloging System (NOC) with the NCAGE code SFKU3 for our CMCE SERTEC lightning rods.
- DUNS REGISTRATION Number 955067967
- ITE Laboratory Studies under UNE 21186:2011 NFC 17102:2011 standards: (Laboratories with ENAC-ILAC and ISO 17025 Accreditation):
 - High voltage electrical impulse and ignition tests up to a record voltage of 840KV at one meter without tracer formation.
 - Mechanical, Environmental Tests of Salt Fog, in sulfurous atmosphere, current, Priming advance.
- Laboratory studies in the GCC-LAB laboratory in Saudi Arabia under IEC 62305 standards

PROTECTION EFFECTIVENESS

99% reduction in direct lightning strikes on protected structures.

In the event of a lightning strike (1%), the CMCE acts as a thermal fuse, absorbing some of the lightning energy as heat by melting its components, minimizing electromagnetic effects. In this case, SERTEC S.R.L. covers only the replacement and technical assistance of the equipment under warranty (not labor costs).

MECHANICAL CONNECTION TO THE MAST

It incorporates in its axis the mast connection system. The CMCE requires a mast with an inner diameter of 42 mm and an outer diameter of 49 mm, with a through-hole of 8 mm in diameter located 50 mm from the edge of the mast.

COVERAGE RADIUS

120 meters of radius according to each lightning protection needs assessment.

APPLICATIONS

CMCE TWIN MAX, exceeds the high efficiency of its inspiring base, the CMCE 120 for application in the most extreme conditions of electric field, wind turbines, solar parks, structures that are more than 4000 meters above sea level and places with a high ceramic level.

PRODUCT WARRANTY

5 years warranty, subject to annual maintenance. Coverage in case of direct lightning strike on the product. Effects resulting from external induced overvoltages or non-compliance with manufacturer's requirements such as grounding, installation, materials, and correct technical practices (as specified in the installation manual) are excluded from this coverage.

Weight/Dimensions of CMCE-SERTEC:

Weight: 6,4 kg
Measures: Ø 24 cm x 37,1 cm.

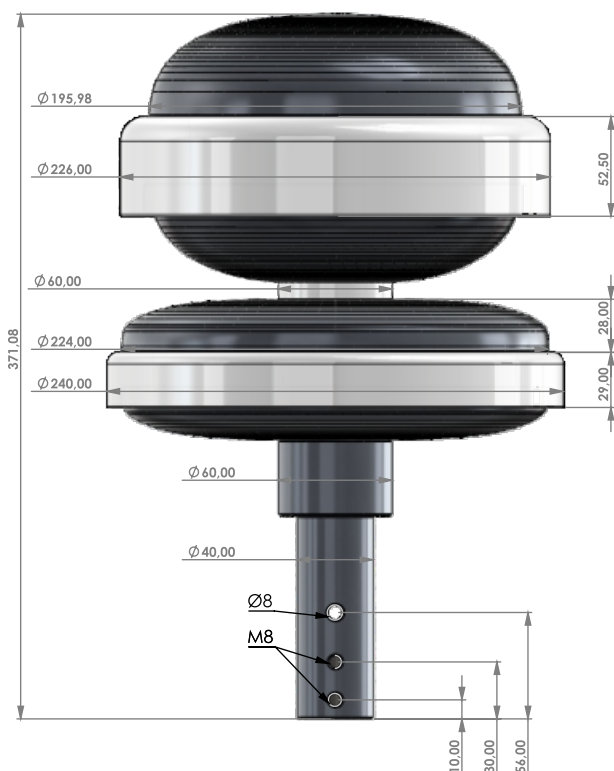

TECHNICAL SUMMARY

Dimensions	CMCE TWIN MAX
Size	Ø 24 cm x 37,1 cm
Net Weight	6.4 Kg
Total Weight	9.45 Kg
Packaging dimensions	28x28x40 cm
Packaging recyclable	100%
Space to connect Down conductor	Ø 20mm (up to 70 mm ² section cross)

Materials and test	CMCE TWIN MAX
Aluminum	95.5% purity
Polyacetal	POM
Inox	ANSI 316
Salt Mist Test	According to UNE-EN 60068-2-52
Humid Sulphurous Atmosphere Test	According to UNE-EN ISO 6988 with 7 cycles and SO ₂ concentration of 667 ppm(for volume)
Max. Temperature without deformation	-65 °C to 140 °C

Electrical Characteristics	CMCE TWIN MAX
Coverage Radius	120 meters
Maximum Voltage	840 KV to 1 meter
Impulse Current	100KA(10/350 µs)
Draining Current Work	0.01 mA to 20A
Voltage work AC/DC	0.01 mV to 20V
Range of Frequency Lab Test	-65 °C to 140 °C
Power Supply	Not necessary
Ambiental Temperature Range	-50 C° to 60 C°

Mounting design	CMCE TWIN MAX
Built-in on its axis to mount to external galvanized pipe.	Ø 39.5 to Ø 49 mm
Side to side transverse perforation in axis for the thru-screw	8mm/10mm
Customizable base fixing for special support	If is necessary
Down conductor connection.	Built-in space for connection with two M8 screws.